

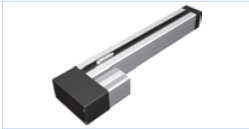



Linear units

Overview

LES functional overview		2-54
LES 4 with spindle drive		2-56
LES 6 with spindle drive		2-58
LES 5 with spindle drive		2-60
Calculations		2-62
Combination examples		2-64
Motor modules		2-66
Clutch housing		2-68
Motor leads		2-70
Installation kit <small>with angular transmission</small>		2-72
Slots/crossbench plates		2-74
T-slot plates		2-77
Angle brackets		2-79
Accessories		2-81
iLD 50-6 with linear motor		2-82

Functional overview

at example LES 5

Plastic cap
electromagnetically shielded

Clamping surface
milled flat

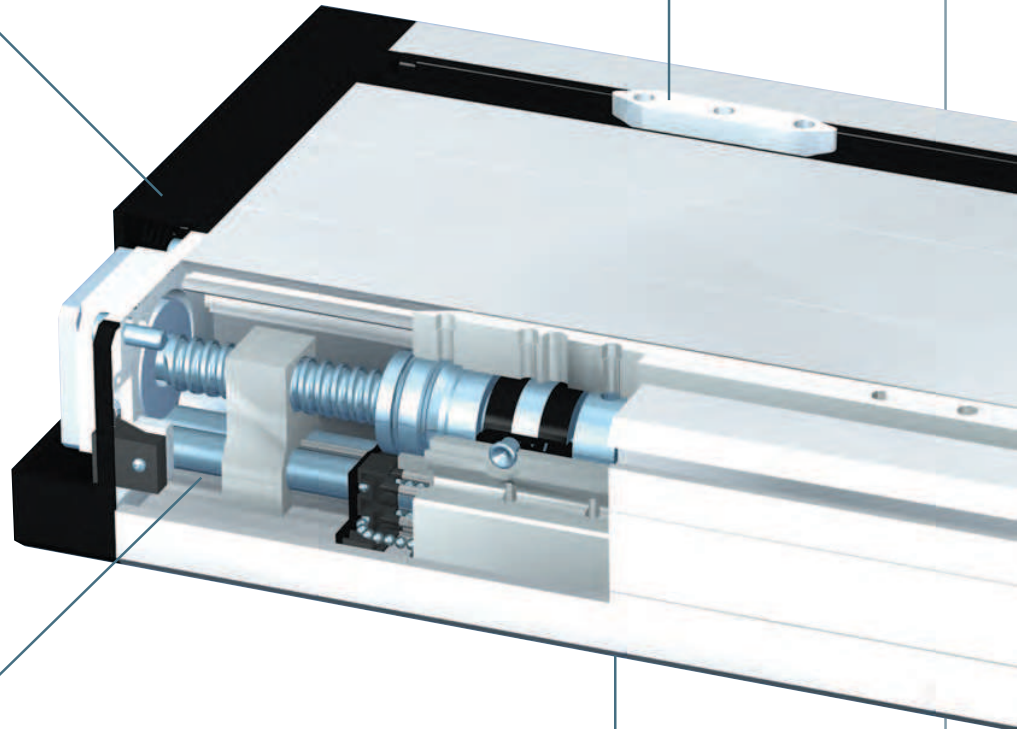

Shaft housing outline
precision milled

Profile underside
milled flat



- End position buffering both sides with soft PVC parabolic springs
- Counter-bearing with 2 needle sleeves



- Spindle support from a profile length of 1500 mm without limiting the process range

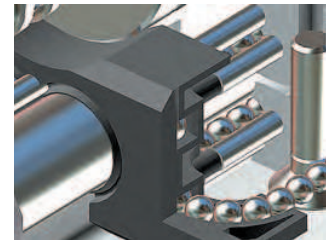

- Recirculating ball in patented aluminium linear slides
- Glass fibre reinforced loop components with scrapers

Functional overview

at example LES 5

Friction-resistant lip seals
to protect the guide elements

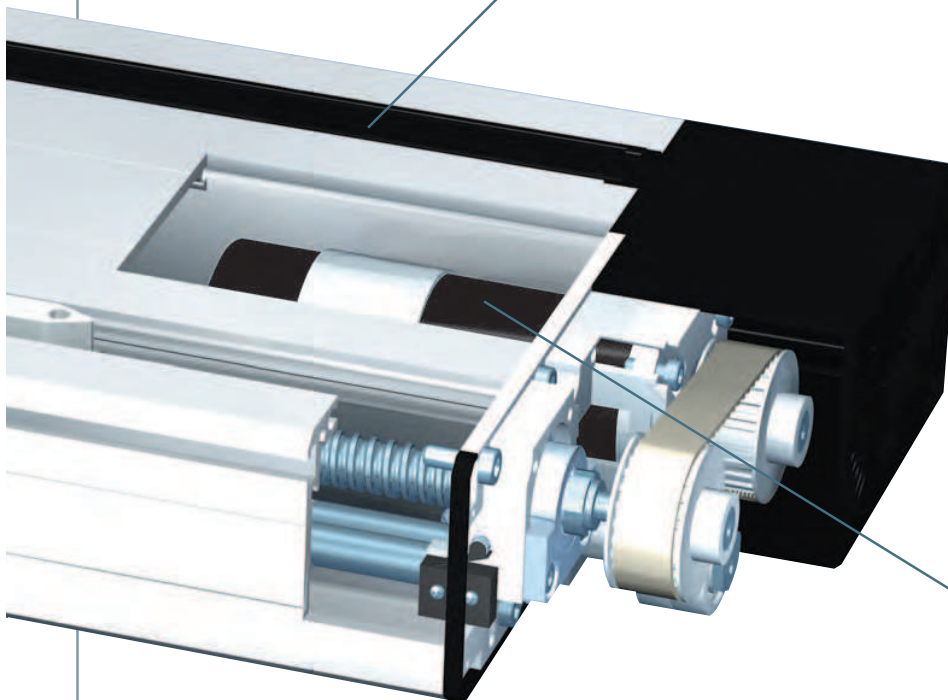

Motor
incorporated in the profile

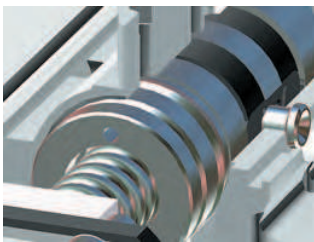

- Preset play-free recirculating ball nut with scrapers
- Central lubrication system for recirculating ball nut and circulations



- Integrated overrun limit switch
- Spindle bearing with angular contact bearings
- Axially free from play by means of self-locking special nuts

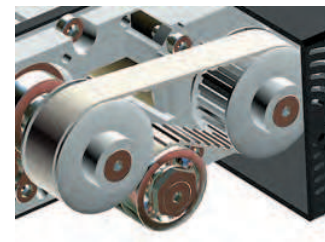

- Belt return and connecting electronics covered completely by protective cap

Linear units with spindle drive

LES 4

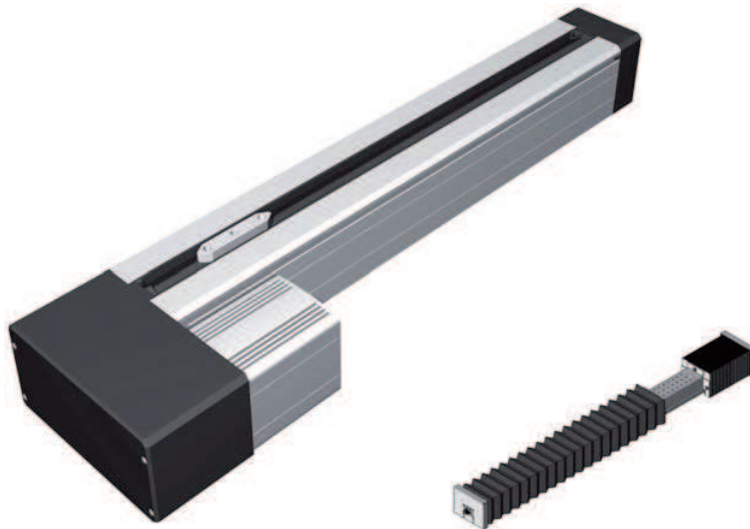

LES 4 with side-mounted belt drive module

LES 4 - bellows gaiter option

Features

- Aluminium shaft housing profile W75 × H75 mm, naturally anodised
- Clamping area and profile underside milled flat
- with 2 precision steel shafts Ø 12 h6, material Cf53, Hardness 60 ± 2 HRC
- Aluminium shaft slides WS 5/70, 2 x WS 5/70 (70 mm long), adjustable for no play, central lubrication system
- Recirculating ball drive 2.5/4/5/10 and 20 mm pitches
- Profile sealing with friction-resistant lip seals
- Cast aluminium end plates
- With 2 limit or reference switches, Repeat accuracy ± 0.02 mm
- Sealed angular contact bearings in drive - steel flange

Ordering key

2 3 4 X X X 0 X X X

Drive

- 0 = Preparation Direct drive modules
- 1 = Preparation Belt drive module

Shaft slides

- 0 = 1 Shaft slides 70 mm
- 2 = 2 Shaft slides 70 mm

Profile length (L1)

- e.g. 029 = 290 mm (min.)
- 299 = 2990 mm (max.)

(rounded to the last digit)

Standard profile lengths available in 100 mm raster

Recirculating ball drive

- 0 = without
- 1 = Pitch 2.5 mm
- 2 = Pitch 4.0 mm
- 3 = Pitch 5.0 mm
- 4 = Pitch 10 mm
- 5 = Pitch 20 mm

Options:

- Black anodized aluminium profile
- Electromagnetic brakes in the motor module or in drive spindle extension
- Steel slide LS2 (Part no. 223007)
- External limit switch attachment set (see accessories)

Available on request:

- Length measuring system
- Bellows gaiter cover
- Assembly left of the motor module

Drive modules

see pages 2-66 et seq. of the catalogue

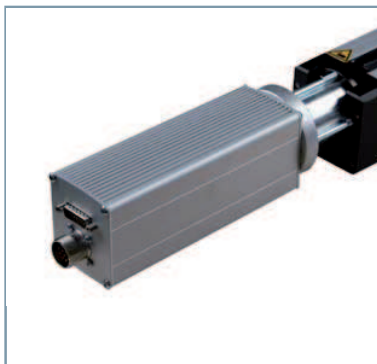

Technical specification

Aluminium profile

Aluminium profile LES 4	
Moment of inertia I _x	107.711 cm ⁴
Moment of inertia I _y	125.843 cm ⁴
*Centre of gravity <small>see dimensioned drawing</small>	33.23 mm
Cross-sectional area	18.81 cm ²
Material	AlMgSiO, 5F22
Anodising	E6/EV1
Weight with steel shafts	6.2 kg/m
Weight with steel shafts and spindles	7.6 kg/m

No load running torques

No load torques (Ncm)					
Speed (rpm)	Spindle pitch				
	2.5	4	5	10	20
500	15	15	16	17	18
1500	19	19	19	20	21
3000	23	24	24	25	26

Linear units with spindle drive

LES 4

Bending

■ Load config. 1

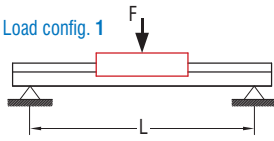

■ Load config. 2

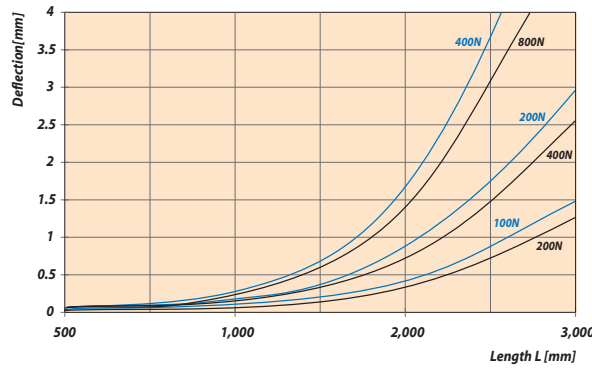
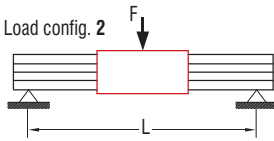

Load factors

$$F_r(\alpha) = \frac{F_2}{\cos \alpha}$$

$$F_r(\alpha) = \frac{F_1}{\sin \alpha}$$

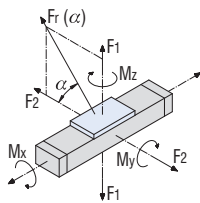

LES 4 with one WS 5/70	
C_o	2576.65 N
C	1461.14 N
F_1 stat.	2200.67 N
F_1 dyn.	1247.93 N
F_2 stat.	2576.65 N
F_2 dyn.	1461.14 N
M_x stat.	36.45 Nm
M_y stat.	82.16 Nm
M_z stat.	96.20 Nm
M_x dyn.	20.67 Nm
M_y dyn.	46.59 Nm
M_z dyn.	54.55 Nm

LES 4 with two WS 5/70	
C_o	4,954.5 N
C	2,809.5 N
F_1 stat.	4,231.5 N
F_1 dyn.	2,398.5 N
F_2 stat.	4,954.5 N
F_2 dyn.	2,809.5 N
M_x stat.	44.7 Nm
M_y stat.	126.945 Nm
M_z stat.	148.635 Nm
M_x dyn.	25.2 Nm
M_y dyn.	71.955 Nm
M_z dyn.	84.285 Nm

permissible spindle speeds

LES 4 / 5 / 6	Spindle pitch p [mm]	max. permissible feed speed v permissible [mm/s]				
		2.5	4	5	10	20
Profile length L [mm]	max. permissible spindle speed n [rpm]					
490	4000	167	267	333	667	1333
990	3000	125	200	250	500	1000
1390	1500	63	100	125	250	500
1490 *	3000	125	200	250	500	1000
1990 *	1650	69	110	138	275	550
2490 *	1050	44	70	88	175	350
2990 *	750	31	50	63	125	250

* with spindle support

dimensioned drawing

process travel

at 1 x WS 5/70 = L1 -150 mm
at 2 x WS 5/70 = L1 -280 mm

external limit switches see pages 2-83

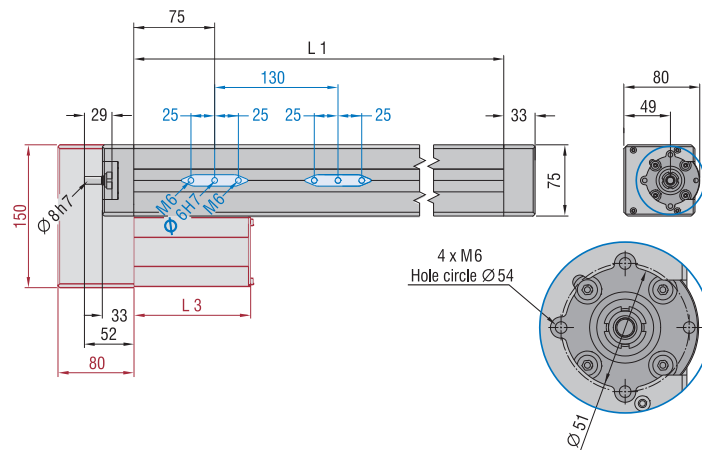

dimensioned drawing

Aluminium profile

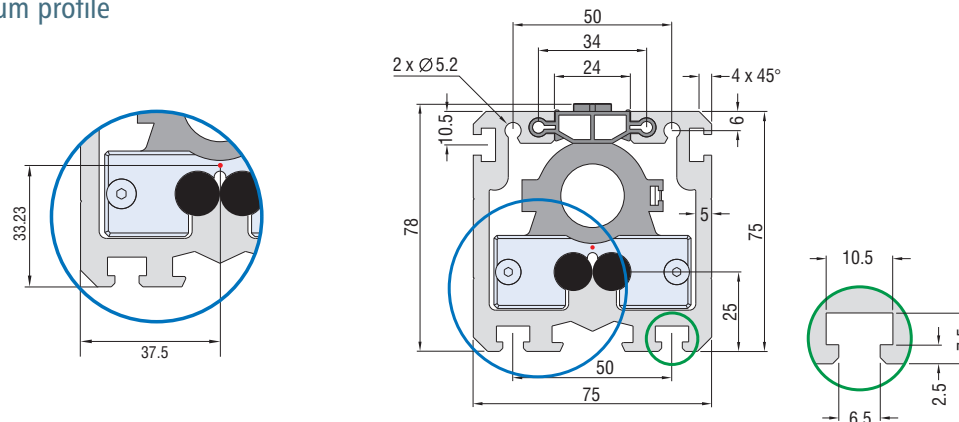

Linear units with spindle drive

LES 6

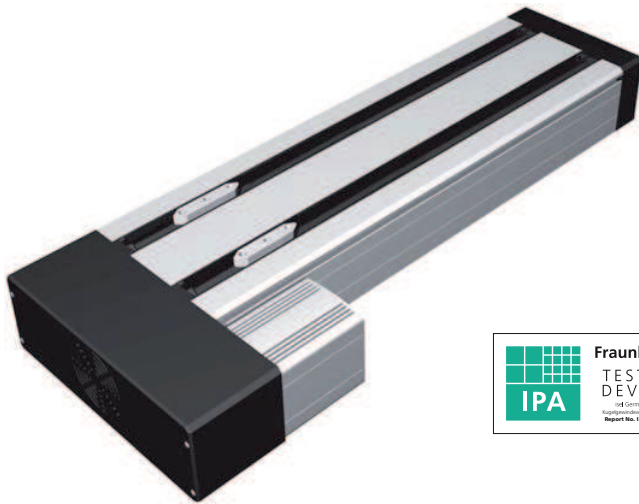

LES 6 with side belt drive module

Features

- Aluminium shaft housing profile W150 × H75 mm, naturally anodised
- Clamping area and profile underside milled flat
- With 4 precision steel shafts Ø 12 h6, material Cf53, Hardness 60 ± 2 HRC
- Aluminium shaft slides WS 5/70, 2 × WS 5/70 (70 mm long), adjustable for no play, central lubrication system
- Recirculating ball drive 2.5/4/5/10 and 20 mm pitches
- Profile sealing with friction-resistant lip seals
- Cast aluminium end plates
- With 2 limit or reference switches, Repeat accuracy ± 0.02 mm
- Sealed angular contact bearings in drive - steel flange

Ordering key

2 3 4 X X X 0 X X X

Drive

- 6 = Preparation Direct drive modules
- 7 = Preparation Belt drive module

Shaft slides

- 0 = 2 Shaft slides 70 mm
- 2 = 4 Shaft slides 70 mm

Profile length (L1)

- e.g. 029 = 290 mm (min.)
- 299 = 2990 mm (max.)

(rounded to the last digit)

Standard profile lengths available in 100 mm raster

Recirculating ball drive

- 0 = without
- 1 = Pitch 2.5 mm
- 2 = Pitch 4.0 mm
- 3 = Pitch 5.0 mm
- 4 = Pitch 10 mm
- 5 = Pitch 20 mm

Options:

- Black anodized aluminium profile
- Electromagnetic brake
- Steel slides LS2 (Part no. 223007)
- Limit switch attachment kit (see accessories)

To order:

- Length measuring system
- Bellows gaiter cover
- Assembly left of the motor module

Drive modules

see pages 2-68 et seq. of the catalogue

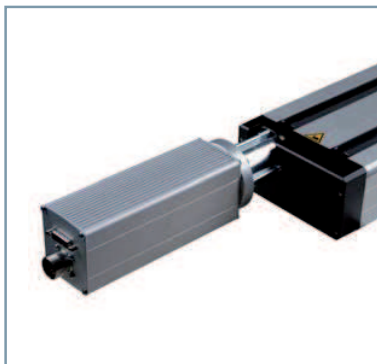

Technical specification

Aluminium profile

Aluminium profile LES 6	
Moment of inertia I _x	707.100 cm ⁴
Moment of inertia I _y	212.200 cm ⁴
*Centre of gravity <small>see dimensioned drawing</small>	32.78 mm
Cross-sectional area	30.07 cm ²
Material	AlMgSiO, 5F22
Anodising	E6/EV1
Weight with steel shafts	11.4 kg/m
Weight with steel shafts and spindles	12.8 kg/m

No load running torques

No load torques (Ncm)					
Speed (rpm)	Spindle pitch				
	2.5	4	5	10	20
500	17	17	18	20	21
1500	20	20	22	24	25
3000	24	25	26	29	30

Linear units with spindle drive

LES 6

Bending

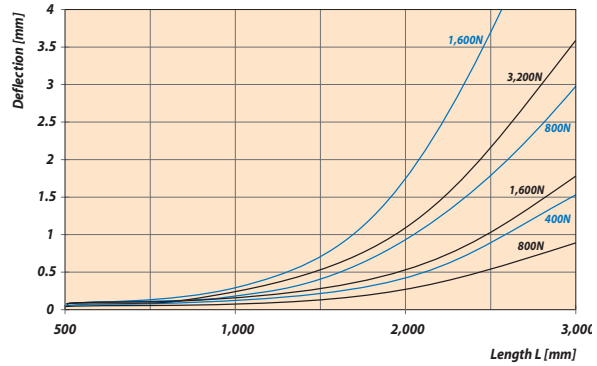
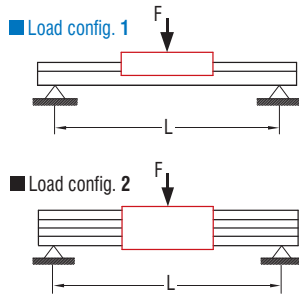

Load factors

$$F_r(\alpha) = \frac{F_2}{\cos \alpha}$$

$$F_r(\alpha) = \frac{F_1}{\sin \alpha}$$

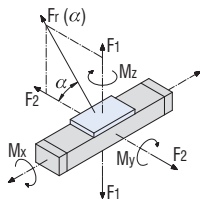

LES 6 with two WS 5/70		LES 6 with four WS 5/70	
C_0	5153.30 N	C_0	6,606 N
C	2319.41 N	C	3,746 N
F_1 stat.	4401.33 N	F_1 stat.	5,642 N
F_1 dyn.	1980.96 N	F_1 dyn.	3,198 N
F_2 stat.	5153.30 N	F_2 stat.	6,606 N
F_2 dyn.	2319.14 N	F_2 dyn.	3,746 N
M_x stat.	211.54 Nm	M_x stat.	211.575 Nm
M_y stat.	164.31 Nm	M_y stat.	366.73 Nm
M_z stat.	192.39 Nm	M_z stat.	429.39 Nm
M_x dyn.	95.21 Nm	M_x dyn.	119.925 Nm
M_y dyn.	73.95 Nm	M_y dyn.	207.87 Nm
M_z dyn.	86.59 Nm	M_z dyn.	243.49 Nm

permissible spindle speeds

LES 4 / 5 / 6	Spindle pitch [mm]	max. permissible feed speed v permissible [mm/s]				
		2.5	4	5	10	20
490	4000	167	267	333	667	1333
990	3000	125	200	250	500	1000
1390	1500	63	100	125	250	500
1490 *	3000	125	200	250	500	1000
1990 *	1650	69	110	138	275	550
2490 *	1050	44	70	88	175	350
2990 *	750	31	50	63	125	250

* with spindle support

dimensioned drawing

process travel

at 2xWS 5/70 = L1 -150 mm
at 4xWS 5/70 = L1 -280 mm

external limit switches see page 2-83

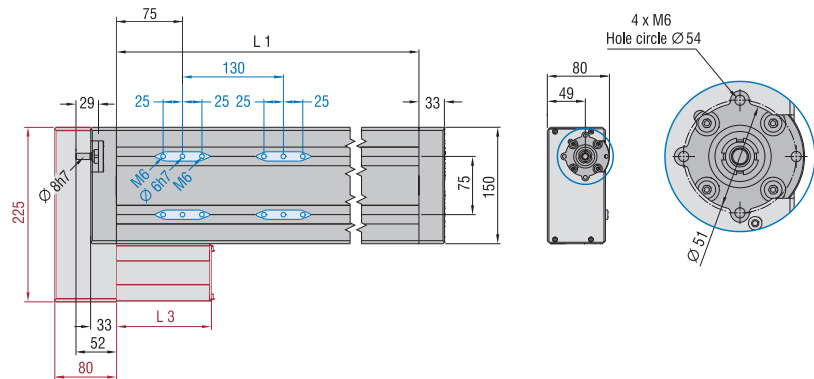

dimensioned drawing Aluminium profile

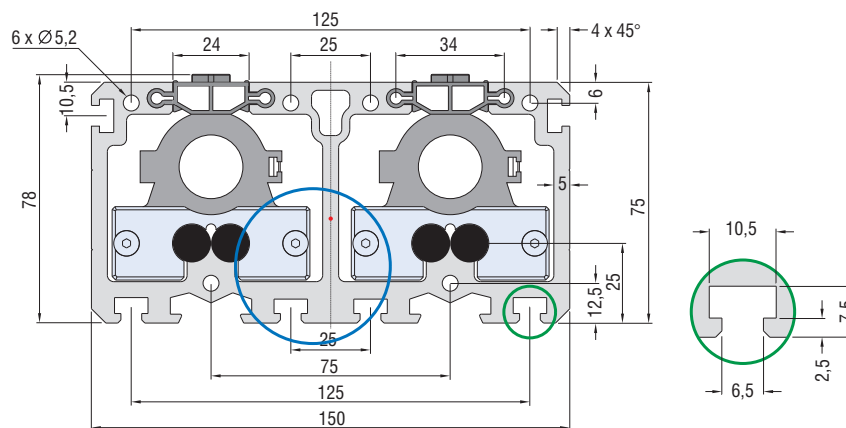
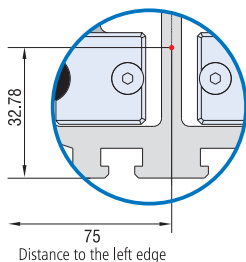

Linear units with spindle drive

LES 5



LES 5 with integrated belt drive module

Features

- Aluminium shaft housing profile W225 × H75 mm, naturally anodised
- Clamping area and profile underside milled flat
- With 4 precision steel shafts Ø 12 h6, material Cf53, Hardness 60 ± 2 HRC
- Aluminium shaft slides WS 5/70, 2 × WS 5/70 (70 mm long), adjustable for no play, central lubrication system
- Recirculating ball drive 2.5/4/5/10 and 20 mm pitches
- Profile sealing with friction-resistant lip seals
- Cast aluminium end plates
- With 2 limit or reference switches, Repeat accuracy ± 0.02 mm
- Sealed angular contact bearings in drive - steel flange

Ordering key

2 3 4 X X X 0 X X X

Drive

- 3 = Preparation Direct drive modules
- 4 = Preparation Belt drive module

Shaft slides

- 0 = 2 Shaft slides 70 mm
- 2 = 4 Shaft slides 70 mm

Profile length (L1)

- e.g. 029 = 290 mm (min.)
- 299 = 2990 mm (max.)

(rounded to the last digit)

Standard profile lengths available in 100 mm raster

Recirculating ball drive

- 0 = without
- 1 = Pitch 2.5 mm
- 2 = Pitch 4.0 mm
- 3 = Pitch 5.0 mm
- 4 = Pitch 10 mm
- 5 = Pitch 20 mm

Options:

- Black anodized aluminium profile
- Electromagnetic brake
- Steel slides LS2 (Part no. 223007)
- Limit switch attachment kit (see accessories)

Available on request:

- Length measuring system
- Bellows gaiter cover

Drive modules

see pages 2-66 et seq. of the catalogue

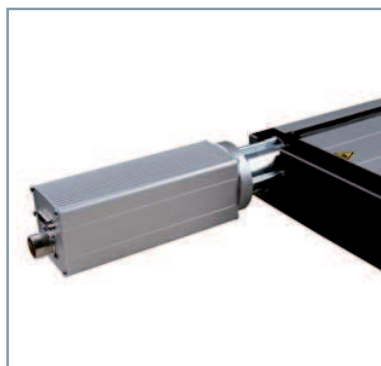

Technical specification Aluminium profile

Aluminium profile LES 5	
Moment of inertia I _x	2,361.654 cm ⁴
Moment of inertia I _y	298.925 cm ⁴
*Centre of gravity <small>see dimensioned drawing</small>	33.39 mm
Cross-sectional area	42.49 cm ²
Material	AlMgSiO, 5F22
Anodising	E6/EV1
Weight with steel shafts	13.8 kg/m
Weight with steel shafts and spindles	15.2 kg/m

No load running torques

No load torques (Ncm)					
Speed (rpm)	Spindle pitch				
	2.5	4	5	10	20
500	15	15	16	17	18
1500	19	19	19	20	21
3000	23	24	24	25	26

Linear units with spindle drive

LES 5

Bending

Load config. 1

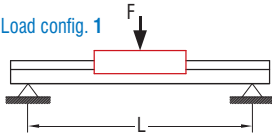

Load config. 2

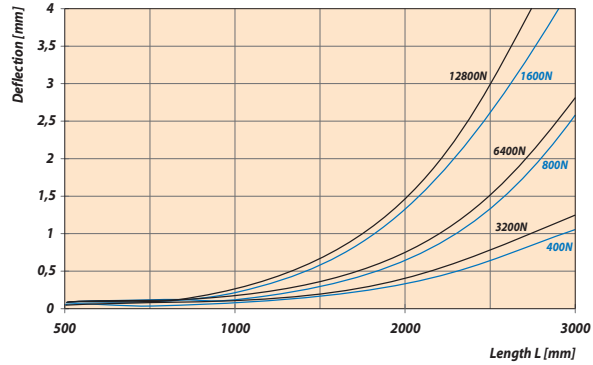
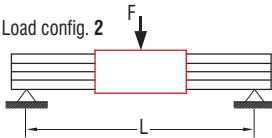

Load factors

$$F_r(\alpha) = \frac{F_2}{\cos \alpha}$$

$$F_r(\alpha) = \frac{F_1}{\sin \alpha}$$

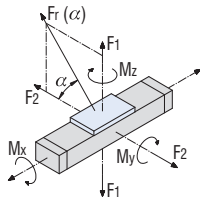

LES 5 with two WS 5/70		LES 5 with four WS 5/70	
C_0	5153.30 N	C_0	6,606 N
C	2319.41 N	C	3,746 N
F_1 stat.	4401.33 N	F_1 stat.	5,642 N
F_1 dyn.	1980.96 N	F_1 dyn.	3,198 N
F_2 stat.	5153.30 N	F_2 stat.	6,606 N
F_2 dyn.	2319.14 N	F_2 dyn.	3,746 N
M_x stat.	376.59 Nm	M_x stat.	423.15 Nm
M_y stat.	164.31 Nm	M_y stat.	366.73 Nm
M_z stat.	192.39 Nm	M_z stat.	429.39 Nm
M_x dyn.	169.49 Nm	M_x dyn.	239.85 Nm
M_y dyn.	73.95 Nm	M_y dyn.	207.87 Nm
M_z dyn.	86.59 Nm	M_z dyn.	243.49 Nm

Permissible spindle speeds

LES 4 / 5 / 6	Spindle pitch p [mm]	max. permissible feed speed v permissible [mm/s]				
		2.5	4	5	10	20
490	4000	167	267	333	667	1333
990	3000	125	200	250	500	1000
1390	1500	63	100	125	250	500
1490 *	3000	125	200	250	500	500
1990 *	1650	69	110	138	275	550
2490 *	1050	44	70	88	175	350
2990 *	750	31	50	63	125	250

* with spindle support

Dimensioned drawing

Process travel

at 2xWS 5/70 = L1 -150 mm
at 4xWS 5/70 = L1 -280 mm

external limit switches see pages 2-81

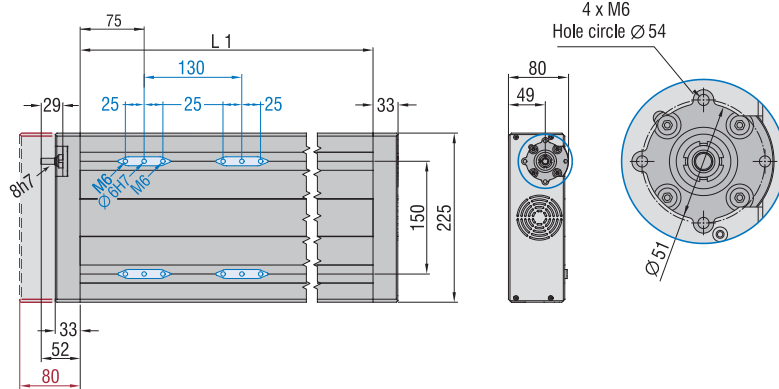

Dimensioned drawing

Aluminium profile

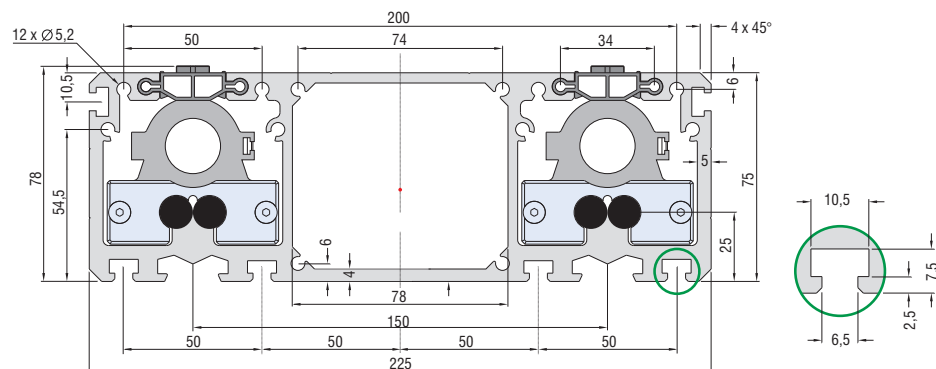

Theoretically critical speed

Calculations

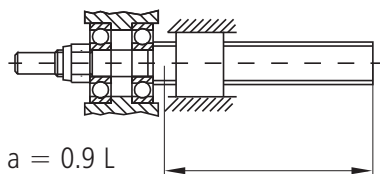
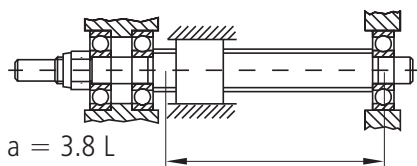

Definitions

n_{perm} [min ⁻¹]	maximum permissible speed
a	Installation coefficient
d_2 [mm]	Spindle core diameter
L [mm]	Spindle length between the spindle bearings and spindle ends

Critical speed

In most applications, you need to check tapped spindles at their critical speed.

The critical speed is that speed which causes resonance oscillations of this spindle.

This critical speed depends on the core diameter, the free load-bearing length and on the way the tapped spindle is constructed.

Given a general safety factor of 0.8, the maximum permissible speed can be calculated as follows:

$$n_{\text{perm}} = 392 \cdot \frac{a \cdot d_2}{L^2} 10^5$$

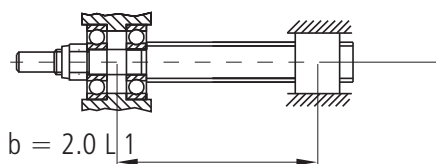
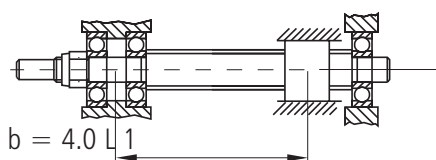

Definitions

F_{perm} [N]	permissible compressive loading
d_2 [mm]	Spindle core diameter
L_1 [mm]	free buckling length, i.e. the maximum distance between the central bearing and the centre of the tapped nut
b	Installation coefficient

Buckling load

The recirculating ball spindle should as far as possible be subjected only to tensile stress. If it is subjected to compressive loads, then the spindle may buckle.

With a safety factor of 3.0 against buckling, the result is

$$F_{\text{zul}} = \frac{34\,000 \cdot b \cdot d_2^4}{L_1^2}$$

Drive dimensioning

Calculations

Drive torque calculation

The required drive torque is made up of

- Load torque M_{load}
- Acceleration torques M_{trans} and M_{rot}
- No load torque $M_{no\ load}$

$$M_A = M_{load} + M_{trans} + M_{rot} + M_{no\ load}$$

Load torque

$$M_{last} = \frac{F_x \cdot p}{2 \cdot \pi \cdot 1000}$$

with feed force $F_x = m \cdot g \cdot \mu$

Translational Acceleration torque

$$M_{trans} = \frac{F_a \cdot p}{2 \cdot \pi \cdot 1000}$$

with feed force $F_a = m \cdot a$

If used vertically, the mass acceleration a must be added to the acceleration due to gravity g ($9.81\ m/s^2$).

Rotational acceleration torque

$$M_{rot} = \frac{J_{sp} \cdot L \cdot n_{max} \cdot a \cdot 2 \cdot \pi}{V_{max} \cdot 60 \cdot 1000}$$

Drive power

$$P = \frac{M_A \cdot n_{max}}{9550}$$

Definitions

M_A	[Nm]	required drive torque
M_{leer}	[Nm]	Torque, resulting from the various loads
M_{leer}	[Nm]	No load torque
M_{rot}	[Nm]	Rotational acceleration torque
M_{trans}	[Nm]	translational acceleration torque
F_x	[N]	Feed force
g	[m/s ²]	Acceleration due to gravity
v_{max}	[m/s]	maximum process speed
m	[kg]	The weight to be conveyed
a	[m/s ²]	Acceleration
p	[mm]	Spindle pitch
P	[kW]	Power
L	[mm]	Length
n_{max}	[rpm]	maximum speed
μ		coefficient of friction
J_{sp}	[kgm ² /m]	Inertial torque of inertia of the spindle per meter
F_a	[N]	Accelerating force

Mechanical specification

Linear unit	LES 4	LES 5	LES 6
Aluminium profile WxH (mm)	75 x 75	225 x 75	150 x 75
Guide weight (kg/m)	6.2	13.8	11.4
Moment of inertia I_x (cm ⁴)	126	299	212
Moment of inertia I_y (cm ⁴)	107	2362	707
Weight with spindle (kg/m)	7.6	15.2	12.8
Guide slides	1x WS 5-70 2x WS 5-70	2x WS 5-70 4x WS 5-70	
Slide weight (kg)	0.34 / 0.68	0.68 / 1.36	
Spindle pitch (mm)	2.5 / 4 / 5 / 10 / 20		
Max. permissible feed force (N)	2626 / 3450 / 3450 / 3150 / 1425		
Repeat accuracy (mm)	± 0.02		
Process path (mm)	L 1 - 150 / L 1 - 280		
Noise level (dBA)	< 85		
Storage temperature range (°C)	0 - 40		
Operating temperature range (°C)	0 - 60 (80)		
Relative air humidity (%)	< 90		

Combination examples

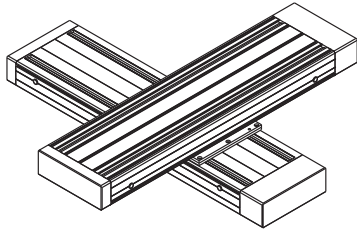

Crossbench

2 × LES 5
PS 4 with VP 2
Slide on slide assembly

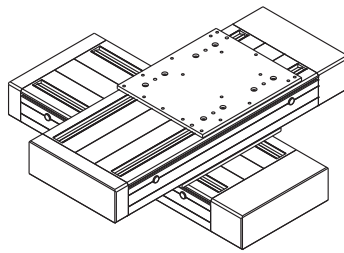

Crossbench

2 × LES 5
VP 2 with PS 4

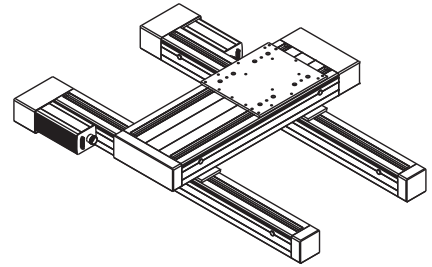

2-axis H-design

2 x LES 4, LES 5, 2 x PS 6, PS 4,
gantry mode

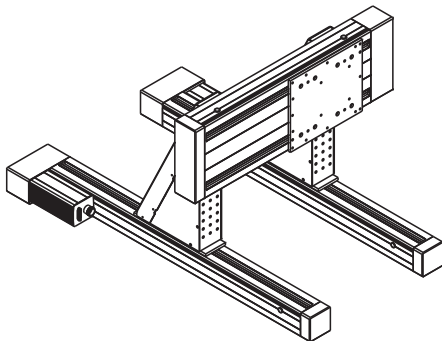

2-axis flatbed configuration

2 x LES 4, LES 5, 2 X PS 2
2 x WV 2, PS 4, gantry mode

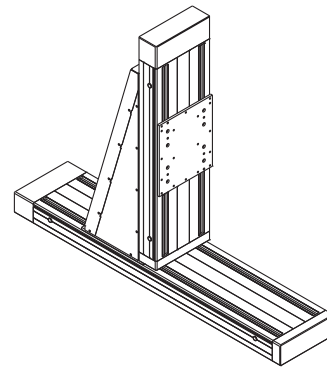

2-axis lifting configuration

2 × LES 5, 2 × PS 4
WV 6

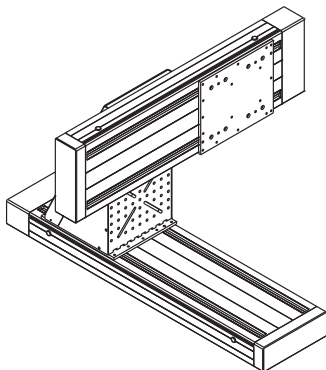

2-axis boom configuration

2 × LES 5
2 × PS 4
WV 3

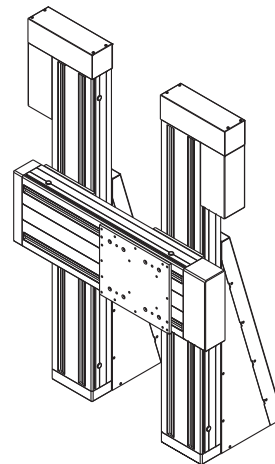

2-axis H-design

LES 5, 2 x LES 6, 2 x WV 7,
2 x PS 12, PS 4, gantry mode

Combination examples

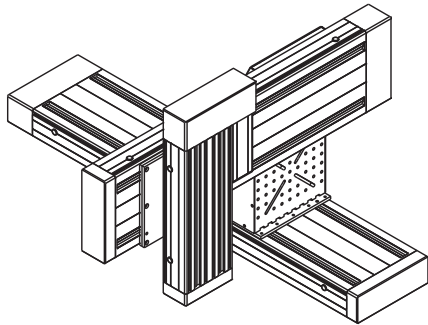

3 axis boom configuration

2 × LES 5, LES 6, WV 3, 2 × PS 4, PS 7

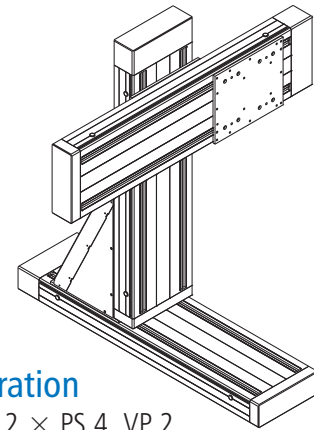

3-axis raised boom configuration

3 × LES 5, WV 3, 2 × PS 4, VP 2

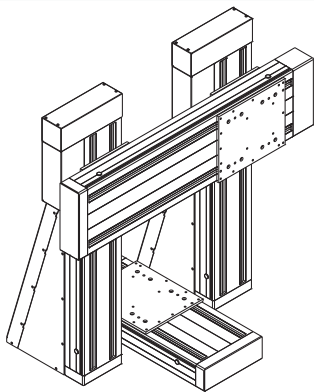

3-axis portal configuration

2 × LES 5, 2 × LES 6, 2 × WV 7,
2 × PS 4, PS 12, gantry mode

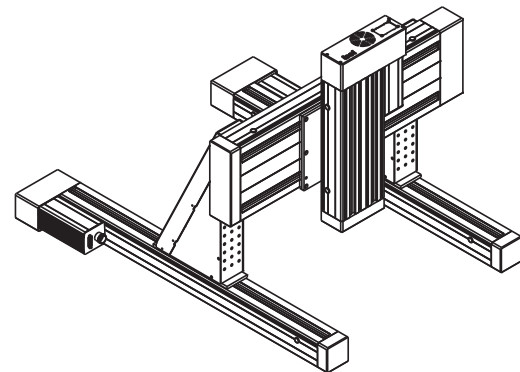

3-axis flatbed configuration

2 × LES 4, LES 5, LES 6, 2 × PS 2, 2 × WV 2,
PS 4, PS 7, gantry mode

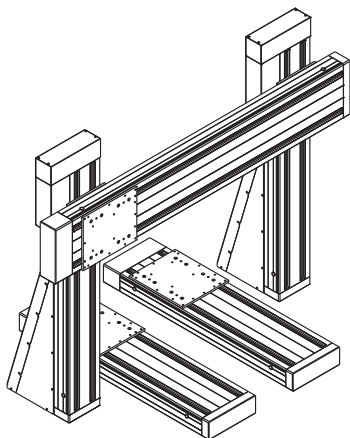

4-axis portal configuration

3 × LES 5, 2 × LES 6, 2 × WV 7,
3 × PS 4, 2 × PS 12

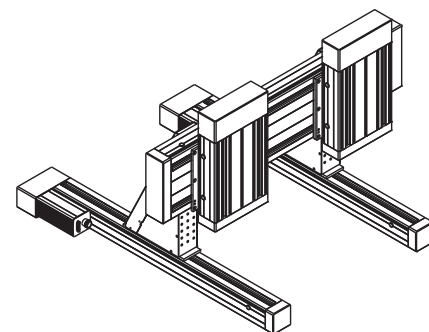

5-axis flatbed configuration

2 × LES 5 (Z-axis), LES 5 (2 spindle drives)
2 × LES 4, 2 × PS 2, 2 × WV 2,
2 × PS 4 with VP 2

Motor modules

Ordering overview

LES 4/5/6 direct drives	Circular plug	Circular plug with brake	Single axis controller	Multiple axis controller
DC servomotor DC 100	396112 0060	-	MC 1-10	iCU-DC / iPU-DC
Stepper motor MS 200 HT - 2	396058 0060	396058 0260	IT 116 Flash	iMC-P / iMC-S8
EC servomotor EC 60S	396415 0060	396415 0260	MC 1-20	iCU-EC / iPU-EC
EC servomotor EC 60L 48V	396423 0060	-	MC 1-20	iCU-EC / iPU-EC
EC servomotor EC 60L 310V	396423 0070	396423 0270	MC 1-40	iCU-EC / iPU-EC
EC servomotor EC 86L	396466 0070	-	MC 1-40	Switching cabinet
EC servomotor EC 86S	396444 0070	-	MC 1-40	Switching cabinet
Stepper motor MS 300 HT - 2	396082 0060	396082 0260	iMC-S8	iMC-S8
Stepper motor MS 600 HT	396085 0060	-	iMC-S8	iMC-S8
Stepper motor MS 900 HT	396088 0060	-	iMC-S8	iMC-S8
LES 5 integrated	Circular plug	Circular plug with brake	Single axis controller	Multiple axis controller
Stepper motor MS 200 HT - 2	396058 1060	396058 1260	IT 116 Flash	iMC-P / iMC-S8
DC servomotor DC 100	396112 1060	-	MC 1-10	iCU-DC / iPU-DC
EC servomotor EC 60S	396415 1060	396415 1260	MC 1-20	iCU-EC / iPU-EC
EC servomotor EC 60L 48V	396423 1060	-	MC 1-20	iCU-EC / iPU-EC
EC servomotor EC 60L 310V	396423 1070	396423 1270	MC 1-40	Switching cabinet
LES 4/LES 6 side mounting	Circular plug	Circular plug with brake	Single axis controller	Multiple axis controller
Stepper motor MS 200 HT - 2	396058 2060	396058 2260	IT 116 Flash	iMC-P
DC servomotor DC 100	396112 2060	-	MC 1-10	iCU-DC
EC servomotor EC 60S	396415 2060	396415 2260	MC 1-20	iCU-EC
EC servomotor EC 60L 48V	396423 2060	-	MC 1-20	iCU-EC
EC servomotor EC 60L 310V	396423 2070	396423 2270	MC 1-40	iCU-EC

Motor modules

dimensioned drawing

Motor module 1

Part no.	Motor module	Length L
396112 0060	DC 100	185 mm
396058 0360	MS 200 HT-2 with brake	165 mm
396058 0060	MS 200 HT-2 without brake	105 mm

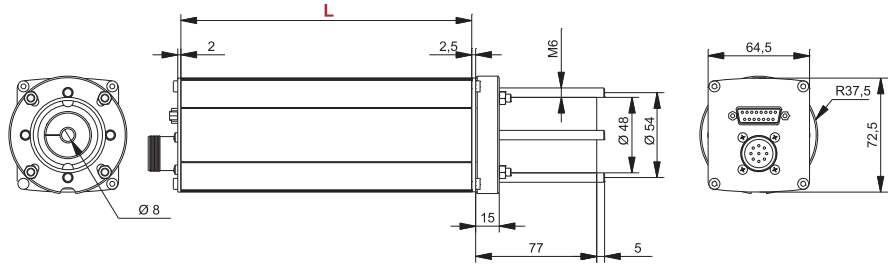

dimensioned drawing

EC 60

Part no.	Motor module	Length L
396415 0260	EC 60S with brake	99 mm
396415 0060	EC 60S without brake	99 mm
396423 0060	EC 60L 48V	120 mm
396423 0070	EC 60L 310V	120 mm

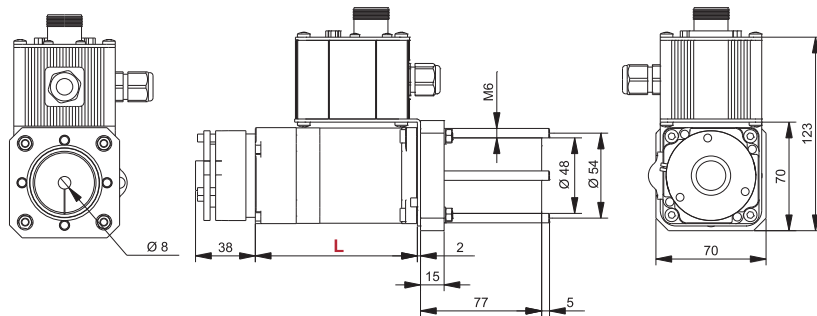

dimensioned drawing

Motor module 2

Part no.	Motor module	Length L
396466 0070	EC 86L	151 mm
396444 0070	EC 86S	126 mm
396085 0060	MS 600HT	96 mm
396088 0060	MS 900 HT	126 mm

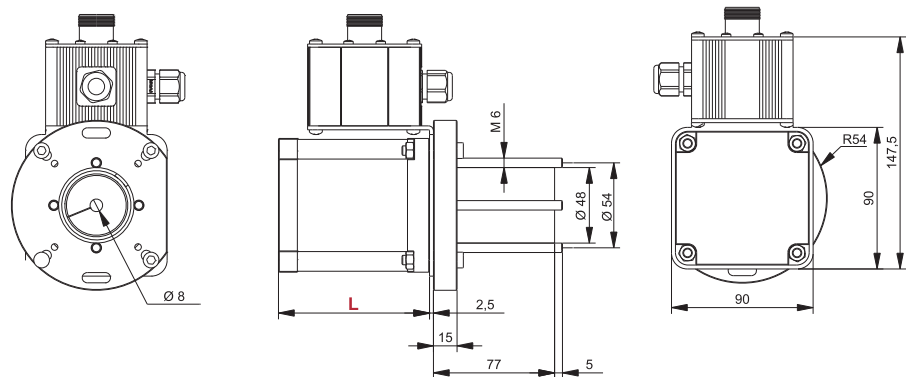

Clutch housing

Drive element accessories

Connection options

Direct drive preparation

Connecting options <i>Direct drive</i>	LES 4	LES 6	LES 5	Angular gear fixing 0°	Angular gear fixing 90°
MS 200 HT-2 DC 100 EC 60	Connection via coupling casing 1 <i>short sleeve</i> with adequate shaft coupling				Coupling casing 1 <i>long sleeve</i>
MS 600 HT MS 900 HT EC 86	Connection via coupling casing 2 <i>short sleeve</i> with adequate shaft coupling				Coupling casing 2 <i>long sleeve</i>
Angular gear fixing 0°	split coupling casing <i>short sleeve</i> with adequate shaft coupling			Connection via transmission shaft set	
Angular gear fixing 90°	split coupling casing <i>short sleeve</i> with adequate shaft coupling				

Ordering overview

Clutch housing

Clutch housing 1

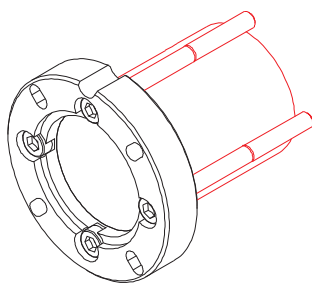

short sleeve
Part no.: 218 100 0001

long sleeve
Part no.: 218 100 0002

Clutch housing 2

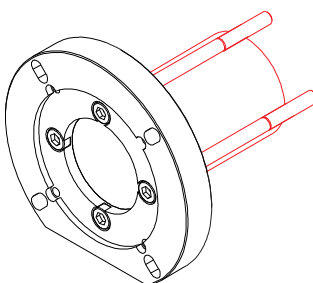

short sleeve
Part no.: 218 100 1001

long sleeve
Part no.: 218 100 1002

Split clutch housing

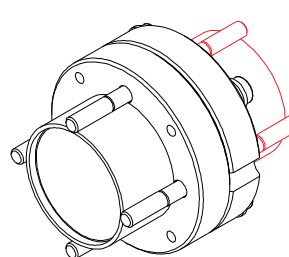

short sleeve
Part no.: 218 100 2001

long sleeve
Part no.: 218 100 2002

Clutches



coupling	Item no.:	d ₁	d ₂
20/30	218 001 5060	5,0	6,0
	218 001 9999	from 4 to 7 mm	
30/40	218 002 6380	6,35	8,0
	218 002 8080	8,0	8,0
	218 002 9999	from 6 to 13 mm	
40/60	218 003 9580	9,52	8,0
	218 003 9999	from 8 to 18 mm	

Clutch housing

Drive element accessories

dimensioned drawing

Coupling casing 1

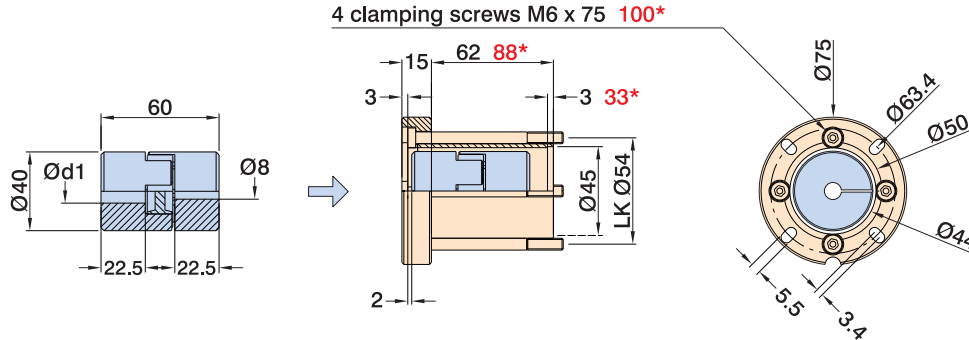

4 clamping screws M6 x 75 100*

*) Measures refer to the dimensions with long sleeves
 d1 = engine shaft diameter 6.35/8/9 mm
 Suitable shaft coupling WK 40/60 on page 2-68 (not included in scope of delivery)

dimensioned drawing

Coupling casing 2

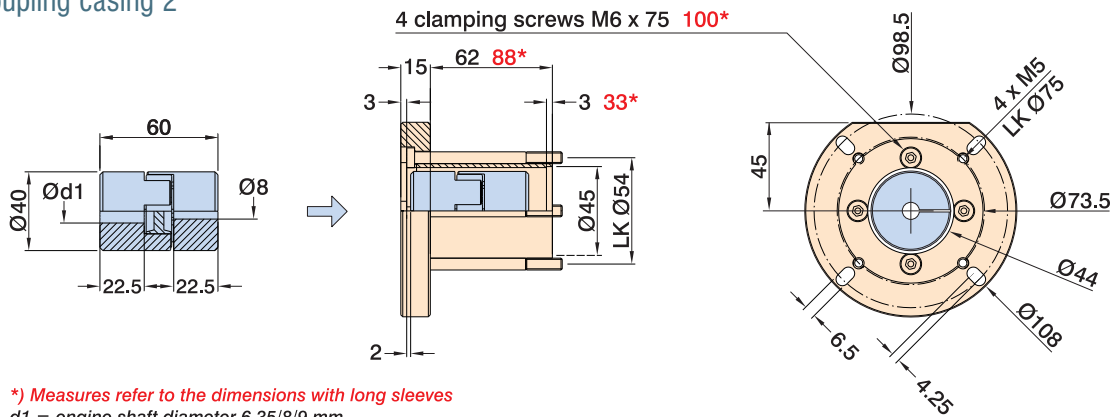

4 clamping screws M6 x 75 100*

*) Measures refer to the dimensions with long sleeves
 d1 = engine shaft diameter 6.35/8/9 mm
 Suitable shaft coupling WK 40/60 on page 2-68 (not included in scope of delivery)

dimensioned drawing

Split coupling casing

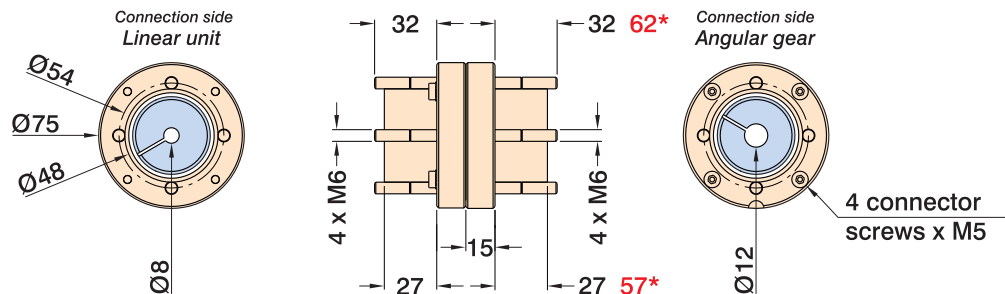

*) Measures refer to the dimensions with long sleeves
 Suitable shaft coupling WK 40/60 on page 2-68 (not included in scope of delivery)

Motor pin assignments

Pin assignment for stepper motors

Motor connection

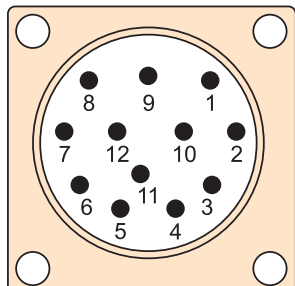

View of pin insert at the insertion side

M23 12-pin Pin	
1	Motor phase 1A
2	Motor phase 1B
3	Motor phase 2A
4	Motor phase 2B
5	+24V switch
6	+24V brake
7	GND switch
8	GND brake
9	Limit switch 1
10	Limit switch 2
11	---
12	---
Housing - cable shield	

Motor connection

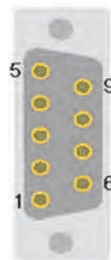

View of pin insert on the socket side

Sub-D 9-pin Pin	
1	Motor phase 1A
2	Motor phase 1B
3	Motor phase 2A
4	Motor phase 2B
5	+24V switch
6	+24V brake
7	Limit switch 2
8	GND brake
9	Limit switch 1
Housing - cable shield	

Pin assignment for DC servo motors with brushes (BDC)

Motor connection

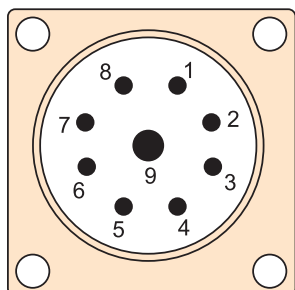

View of pin insert on the socket side

M23 9-pol. (8+1) pin	
1	Motor phase 1 (V+)
2	Motor phase 1 (V-)
3	Motor phase 1 (V+)*
4	Motor phase 1 (V-)*
5	+24V brake
6	GND brake
7	---
8	---
9	Earthing lead
Housing - cable shield	

* Part motor phase connection also by means of 2 wires.

Encoder connection



View of pin insert on the socket side

Sub-D 15-pin Pin	
1	---
2	+5V encoder
3	Encoder track/Z
4	Encoder track/B
5	Encoder track/A
6	+24V switch
7	Limit switch 1
8	GND switch
9	---
10	GND encoder
11	Encoder track Z
12	Encoder track B
13	Encoder track A
14	Reference switch
15	Limit switch 2
Housing - cable shield	

Pin assignment for brushless EC servo motors (BLDC) 48V

Motor connection

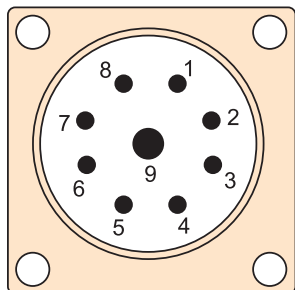

View of pin insert on the socket side

M23 9-pol. (8+1) pin	
1	Motor phase U
2	Motor phase V
3	Motor phase W
4	---
5	+24V brake
6	GND brake
7	---
8	---
9	Earthing lead
Housing - cable shield	

Encoder connection



View of pin insert on the socket side

Sub-D 15-pin Pin	
1	Hall signal A
2	+5V encoder/Hall
3	Encoder track/Z
4	Encoder track/B
5	Encoder track/A
6	+24V switch
7	Limit switch 1
8	GND switch
9	Hall signal B
10	GND encoder
11	Encoder track Z
12	Encoder track B
13	Encoder track A
14	Hall signal C
15	Limit switch 2
Housing - cable shield	

Motor leads

Pin assignment for brushless EC servomotors (BLDC) 310V

Motor connection

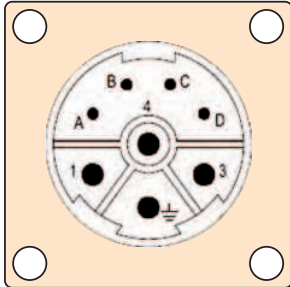

View of pin insert at the insertion side

M23 9-pol. (4+3+1) pin

1	Motor phase U
PE	Earthing lead
3	Motor phase W
4	Motor phase V
A	+24V brake
B	GND brake
C	Temp +
D	Temp -
Housing - cable shield	

Encoder connection



View of pin insert at the insertion side

Sub-D 15-pin Pin

1	Hall signal A
2	+5V encoder/Hall
3	Encoder track/Z
4	Encoder track/B
5	Encoder track/A
6	+24V switch
7	Limit switch 2
8	GND switch
9	Hall signal B
10	GND encoder
11	Encoder track Z
12	Encoder track B
13	Encoder track A
14	Hall signal C
15	Limit switch 2
Housing - cable shield	

Overview of motor leads for stepper, DC servo and EC motors*

Part number	Description
392750 0500	5-metre stepper motor lead M23 12-pin plug - socket 1:1
392755 0500	5-metre stepper motor lead D-sub 9-pin plug - M23 12-pin socket
392781 0500	5-metre stepper motor lead D-sub 9-pin plug - socket 1:1
392759 0500	5-metre DC/EC servo motor lead M23 9-pin (8 + PE) plug - socket 1:1
392760 0500	5-metre DC/EC servo motor lead M23 9-pin (8+PE) socket - wire end ferrules
392740 0500	5-metre encoder lead D-sub 15-pin plug - socket 1:1
392325 0500	5-metre encoder lead M23 17-pin socket - D-sub 15-pin plug
392305 0500	3-metre EC/AC servo motor lead M23 310V (4+3+PE) socket - wire end ferrules
392307 0500	5-metre EC servo motor lead M23 (4+3+PE) plug - socket 1:1

All listed motor and encoder leads are fit for use with tow chains.

* Different lengths available on request!

Installation kit with angular transmission

Drive element accessories

Installation alternatives

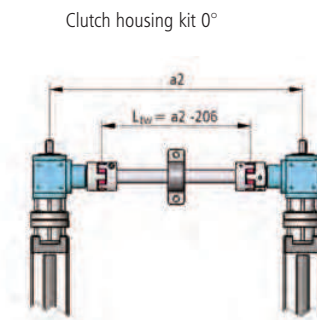
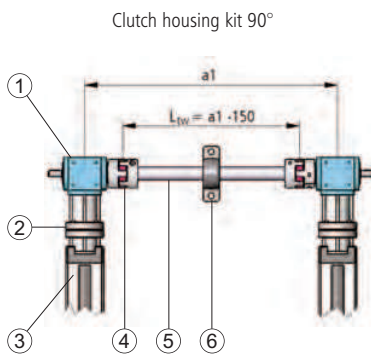

- ① Angular gear
- ② Split coupling casing with shaft coupling WK 40/60
- ③ LES 4, LES 6 or LES 5 (preparation for direct drive)
- ④ Coupling for transmission shaft Ø 25
- ⑤ Transmission shaft Ø 25
- ⑥ Pedestal bearing - recommendable from : transmission shaft length of 1,500 mm up

dimensioned drawing Angular transmission

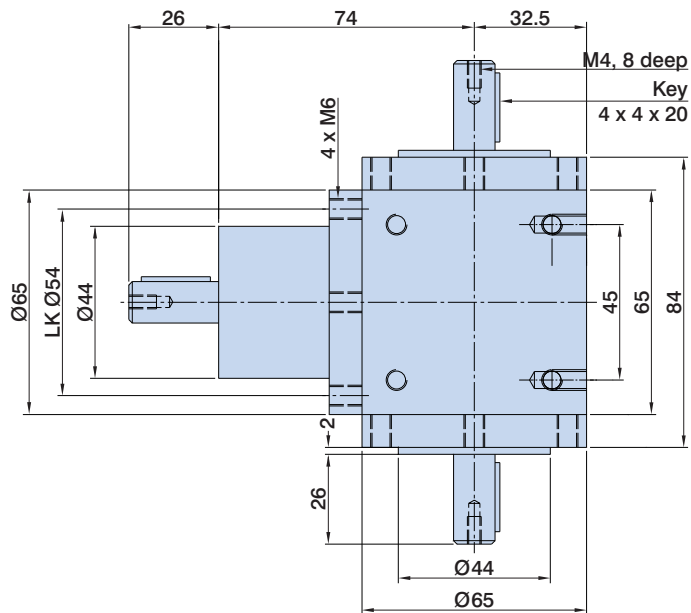
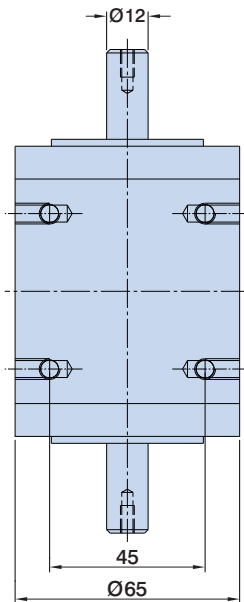

Ordering overview

Installation kit with angular transmission

for H-design on LES 4/LES 6/LES 5,
0° mounting
Scope of delivery: 2 x ①, 2 x ②, 2 x ④
Part no.: **216150 0001**

for H-design on LES 4/LES 6/LES 5,
90° mounting
Scope of delivery: 2 x ①, 2 x ②, 2 x ④
Part no.: **216150 0002**

For matching direct drive modules LES 4/5/6 see table on page 2-66

Transmission shaft

Hollow shaft Ø 25 mm × 4 mm, blank
1000 mm
Part no.: **219001 0125**

Hollow shaft Ø 25 mm × 4 mm, blank
2000 mm
Part no.: **219001 0225**

Coupling/stationary bearing

Coupling for transmission shaft
12 to 25 mm adaptor, VE 2 units
Part no.: **218050 0002**

Stationary bearing for transmission shaft
VE 1 unit
Part no.: **896202 5562**

Installation kit with angular transmission

Drive element accessories

Dimensioned drawing and technical specification

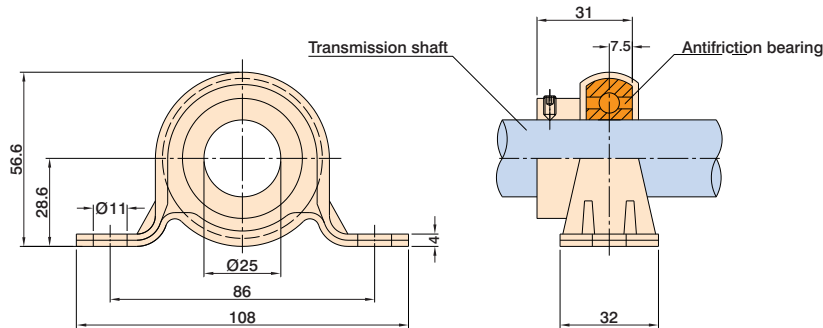

Pedestal bearing- to avoid vibrations/to support the transmission shaft (recommendable from a transmission shaft length of 1,500 mm up)	
Transmissible torque	18 Nm
Weight of coupling	0.3 kg
Weight of shaft	0,540 kg/m
Moment of inertia of both couplings	$2.68 \cdot 10^{-4} \text{ kgm}^2$
Moment of inertia of shaft	$8.171 \cdot 10^{-8} \text{ kgm}^2/100 \text{ mm}$

Dimensioned drawing - coupling

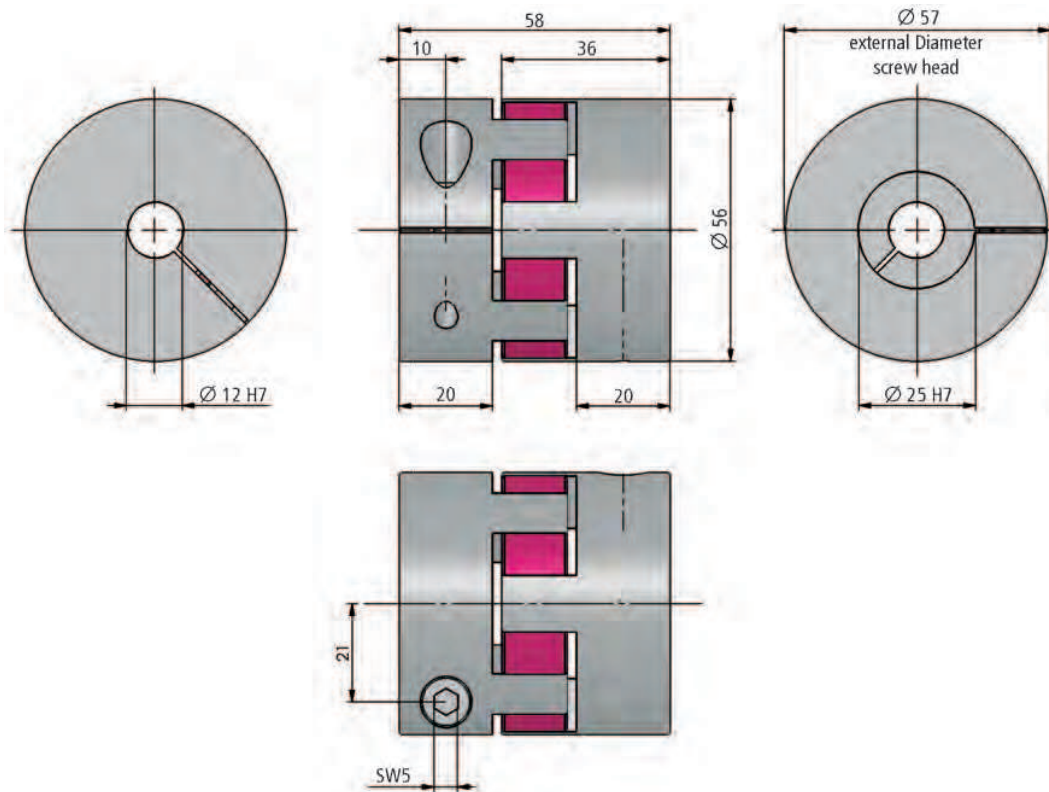

Part no. **218050 0002**

Slide/crossbench plates

Connectors

Hole diagram, slide plate PS 1

L 125 x W 70 x H 7.7 mm

Mounting on:
LES 4 with 1 x WS 5/70

Part no.: **277001**

Connecting cross
2 x LES 4

Part no.: **277007**

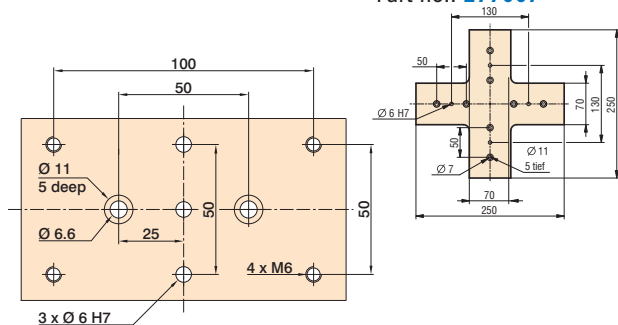

Hole diagram, slide plate PS 2

L 255 x W 70 x H 7.7 mm

Mounting on:
LES 4 with 2 x WS 5/70

Fixing option for:
Angle bracket WV 2 / WV 5

Part no.: **277002**

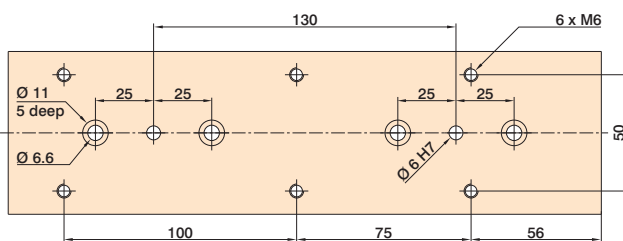

Hole diagram, slide plate PS 3

L 220 x W 125 x H 7.5 mm

Mounting on:
LES 5 with 2 x WS 5/70

Part no.: **277003**

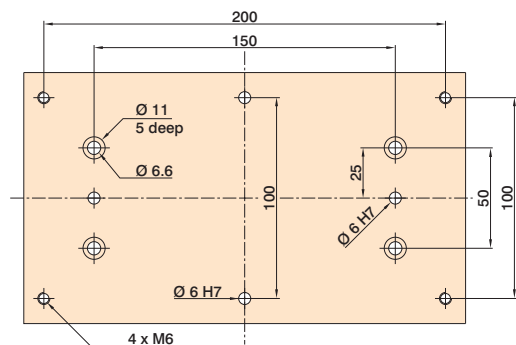

Hole diagram, slide plate PS 4

L 225 x W 220 x H 7.5 mm

Mounting on: LES 5 with 4 x WS 5/70
Mounting on crossbench: LES 5 with LES 5 (in conjunction with
VP 2) Fixing option for: Angle bracket WV 3 / WV 6

Part no.: **277004**

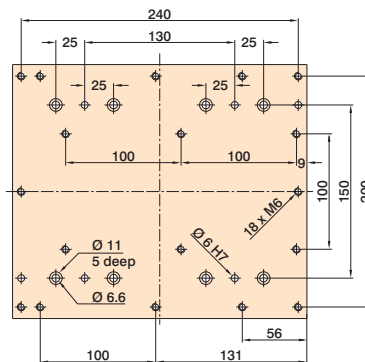

Hole diagram, slide plate PS 6

L 220 x W 125 x H 7.5 mm

Mounting on: LES 4 with 2 x WS 5/70
Mounting on crossbench: LES 4 with LES 5 (in conjunction
with PS 3). Fixing option for: LES 4/LES 5

Part no.: **277011**

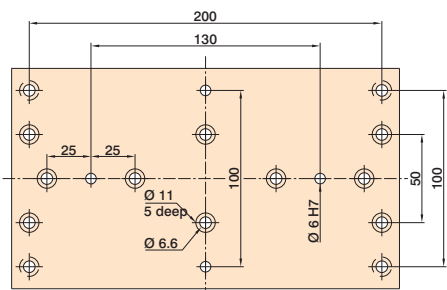

Hole diagram, slide plate PS 7

L 255 x W 220 x H 7.5 mm

Mounting on: LES 6 with 4 x WS 5/70
Mounting on crossbench: LES 6 with LES 5
(in conjunction with PS 4)

Part no.: **277016**

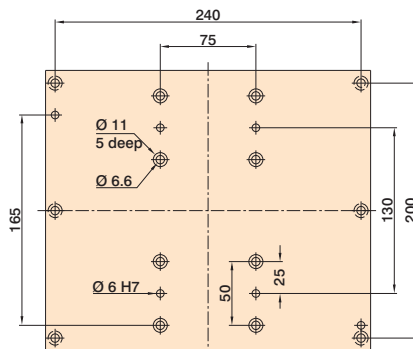

Slide/crossbench plates

Connectors

Hole diagram, slide plate PS 8

L 125 × W 145 × H 7.7 mm

Mounting on:

LES 6 with 2 × WS 5/70 **Part no.: 277017**

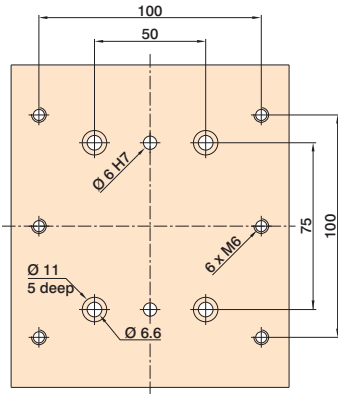

Hole diagram, slide plate PS 9

L 250 × W 145 × H 7.5 mm

Mounting on: LES 6 with 4 × WS 5/70

Fixing option for: Angle bracket WV 7

Part no.: 277018

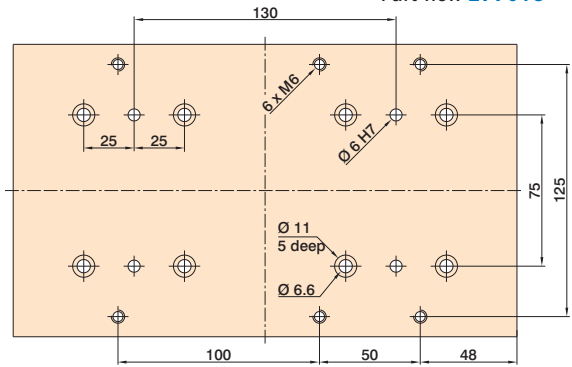

Hole diagram, slide plate PS 10

L 210 × W 215 × H 7.5 mm

Mounting on: LES 6 with 4 × WS 5/70

Mounting on crossbench: LES 6 with LES 6 (in conjunction with PS 11)

Part no.: 277019

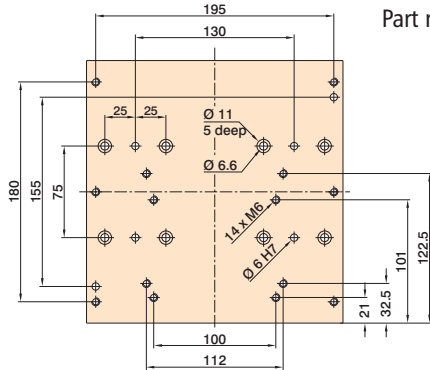

Hole diagram, slide plate PS 11

L 210 × W 215 × H 7.5 mm

Mounting on: LES 6 with 4 × WS 5/70

Mounting on crossbench: LES6 with LES4 (in conjunction with PS10) Fixing option for: LES 6

Part no.: 277020

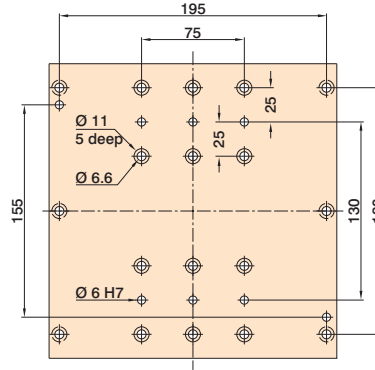

Hole diagram, slide plate PS 12

L 220 × W 180 × H 7.5 mm

Mounting on: LES 6 with 4 × WS 5/70

Fixing option for: LES 5 **Part no.: 277021**

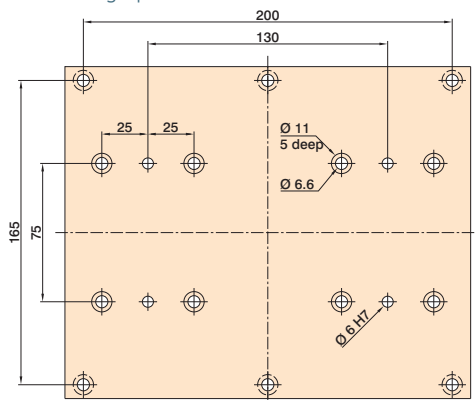

Hole diagram, connection plate VP 2

L 255 × W 220 × H 7.5 mm

Mounting on: LES 5 with 4 × WS 5/70

Fixing option for: LES 5

Part no.: 277006

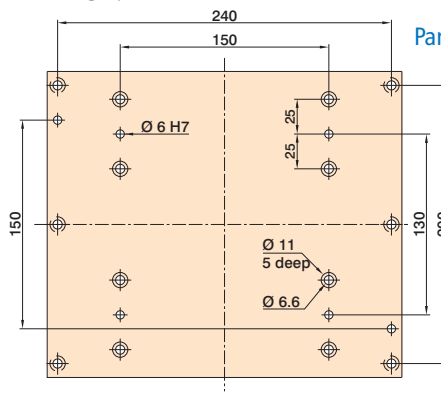

Slide/crossbench plates

Connectors

Hole diagram, slide plate set for crossbench LES 4

L 100 x W 100 x H 8 mm

Mounting on: LES 4
Fixing option for: LES 4

Part no.: **277008**

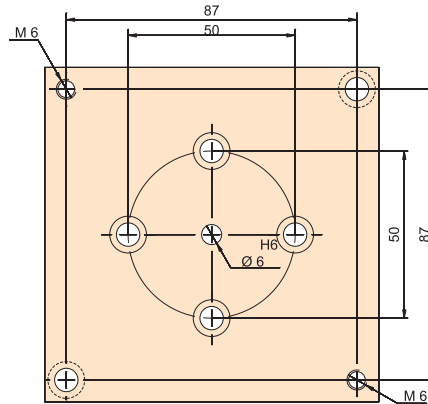

Crossbench connection plates 1

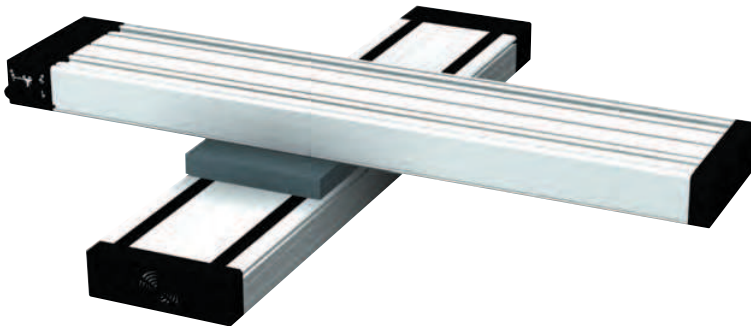

Crossbench connection plates 1

2 × L 255 × W 220 × H 8 mm

one set from PS 4 and VP 2,
for right-angled connection
two linear guides LES 5

Part no.: **277010**

Crossbench connection plates 2

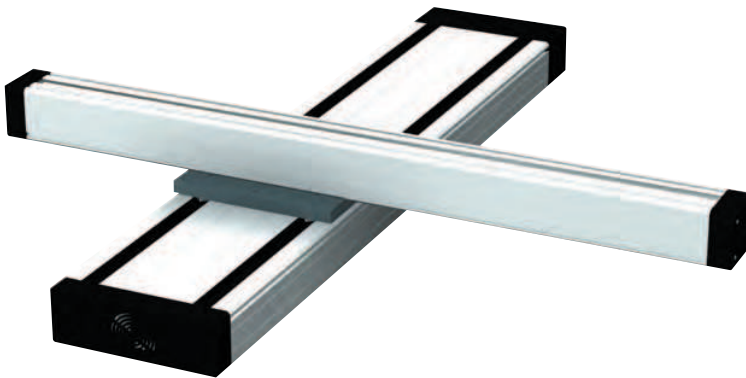

Crossbench connection plates 2

2 × L 220 × W 125 × H 8 mm

one set from PS 3 and PS 6,
for right-angled connection
one linear guide LES 5 with one
linear guide LES 4

Part no.: **277012**

Additional combination examples



Crossbench LES 5 and LES 6
PS 4 and PS 7



Crossbench 2 × LES 6
PS 10 and PS 11



Crossbench LES 4 and LES 6
PS 11 and PS 10

T-slot slide plates

Connectors

Hole pattern T-slot plate PT 25 × 250 for LES 4

L 100 x W 75 x H 20 mm

Mounting on: LES 4 with 1 x WS 5/70

Part no.: **277030 0001**

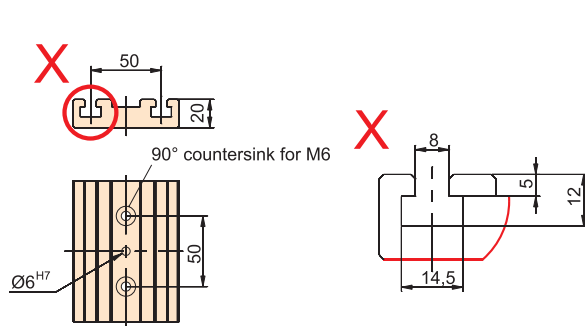

L 200 x W 75 x H 20 mm

Mounting on: LES 4 with 2 x WS 5/70

Part no.: **277030 0002**

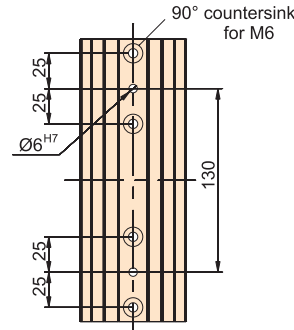

Hole pattern T-slot plate PT 25 × 250 for LES 6

L 100 x W 125 x H 20 mm

Mounting on: LES 6 with 2 x WS 5/70

Part no.: **277030 0003**

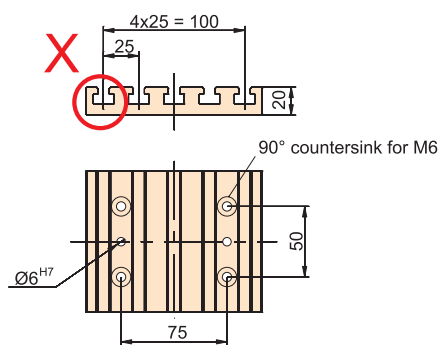

L 200 x W 125 x H 20 mm

Mounting on: LES 6 with 4 x WS 5/70

Part no.: **277030 0004**

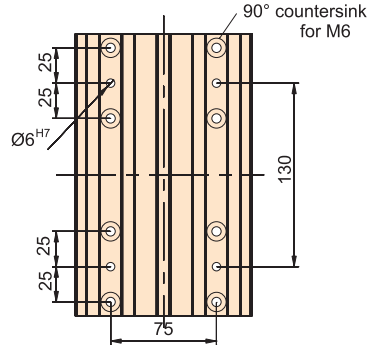

Hole pattern T-slot plate PT 25 × 250 for LES 5

L 100 x W 250 x H 20 mm

Mounting on: LES 5 with 2 x WS 5/70

Part no.: **277030 0005**

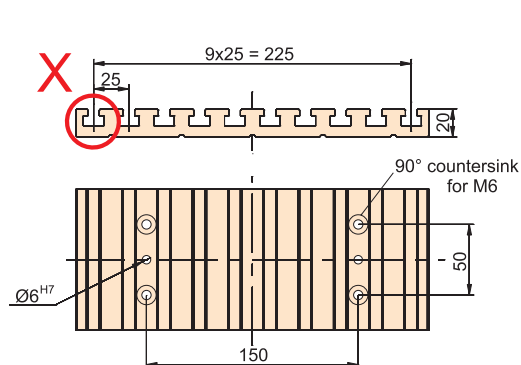

L 200 x W 250 x H 20 mm

Mounting on: LES 5 with 4 x WS 5/70

Part no.: **277030 0006**

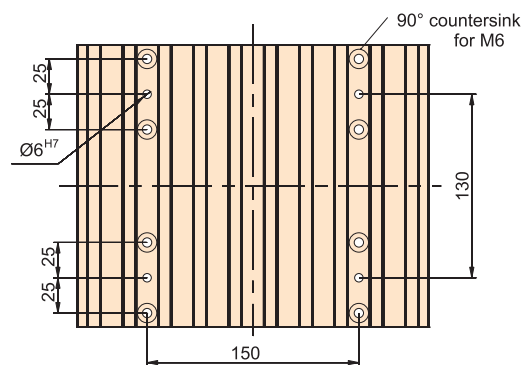

Angle brackets

Connectors

Angle bracket with clamping surfaces milled flat

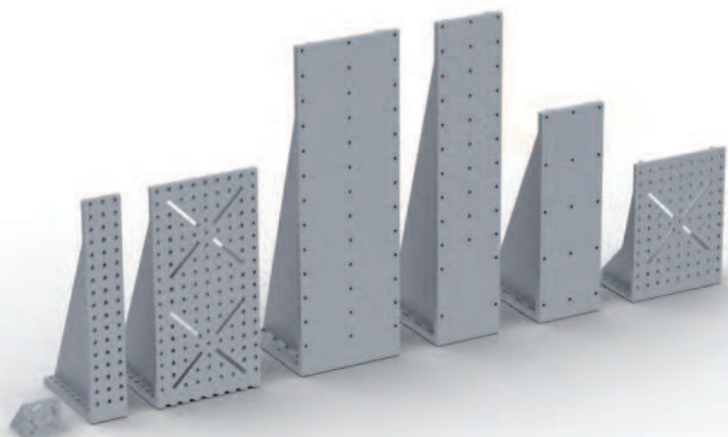

WV 1 WV 2 WV 3 WV 6 WV 7 WV 8 WV 19

matching cover plates

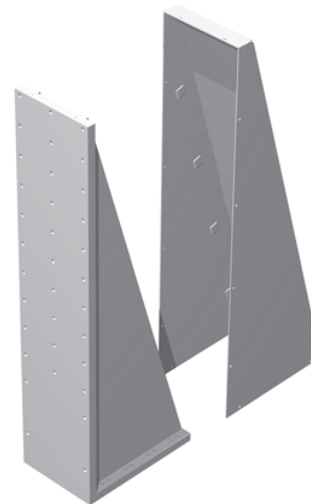

Angle bracket WV 1

- blank
- Aluminium casting (0.2 kg)
- L71 × W75 × H71

Part no.: **209110 0010**

Angle bracket WV 2

- blank
- Aluminium casting (2.6 kg)
- L221 × W75 × H446

Part no.: **209110 0022**

Angle bracket WV 3

- blank
- Aluminium casting (5.8 kg)
- L221 × W221 × H446

Part no.: **209110 0032**

Angle bracket WV 6

- blank
- Aluminium, welded (13.3 kg)
- L220 × W220 × H670

Part no.: **209110 0060**

Angle bracket WV 7

- blank
- Aluminium, welded (10.8 kg)
- L220 × W145 × H670

Part no.: **209110 0070**

Angle bracket WV 8

- blank
- Aluminium, welded (7.4 kg)
- L222 × W145 × H446

Part no.: **209110 0080**

Angle bracket WV 19

- blank
- Aluminium, welded (2.5 kg)
- L150 × W221 × H300

Part no.: **209110 0190**

Cover plate for WV 2

- Naturally anodised
- Aluminium sheet, weight 0.8 kg

Part no.: **209110 0021**

Cover plate for WV 3

- Naturally anodised
- Aluminium sheet, weight 1.15 kg

Part no.: **209110 0031**

Cover plate for WV 6

- Naturally anodised
- Aluminium sheet, weight 1.8 kg

Part no.: **209110 0061**

Cover plate for WV 7

- Naturally anodised
- Aluminium sheet, weight 1.5 kg

Part no.: **209110 0071**

Cover plate for WV 8

- Naturally anodised
- Aluminium sheet, weight 1 kg

Part no.: **209110 0081**

Angle bracket

Connectors

Hole diagram

Angle bracket WV 1

L 71 x W 75 x H 71 mm

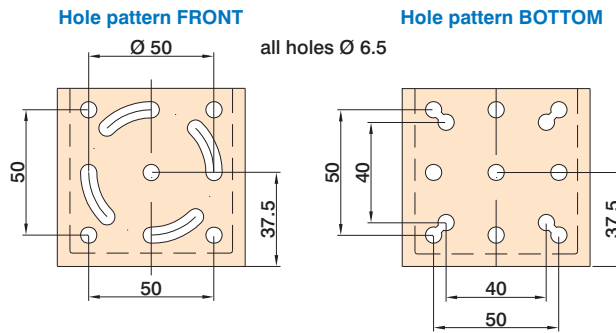

Hole diagram

Angle bracket WV 2

L 221 x W 75 x H 446 mm

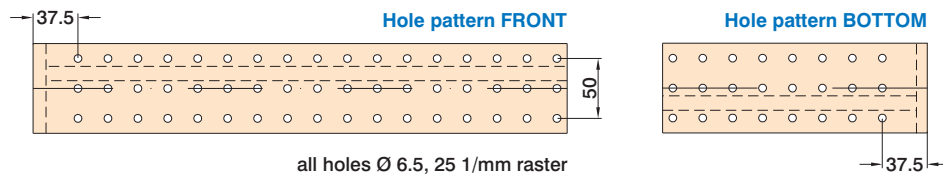

Hole diagram

Angle bracket WV 3

L 221 x W 221 x H 446 mm

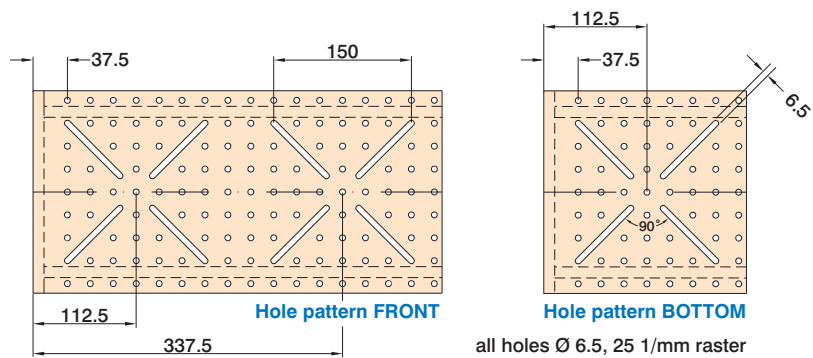

Angle brackets

Connectors

Hole diagram

Angle bracket WV 6

L 220 x W 220 x H 670 mm

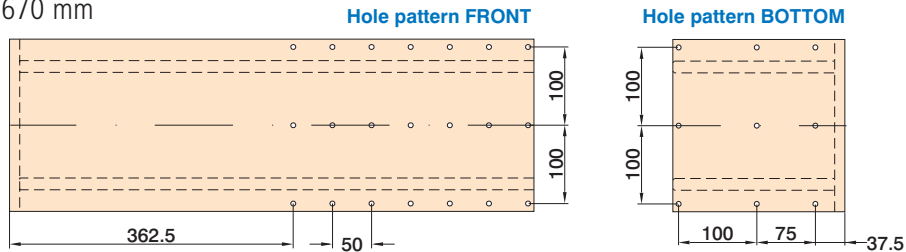

Hole diagram

Angle bracket WV 7

L 220 x W 145 x H 670 mm

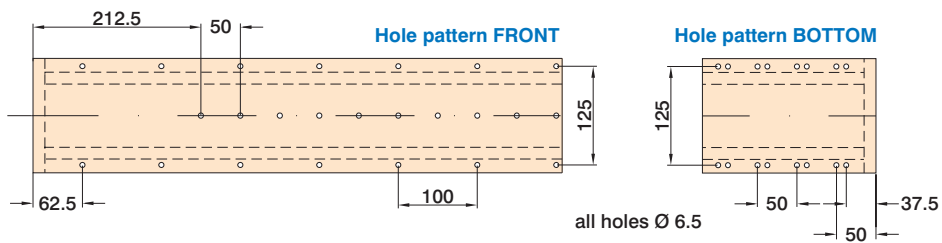

Hole diagram

Angle bracket WV 8

L 222 x W 145 x H 446 mm

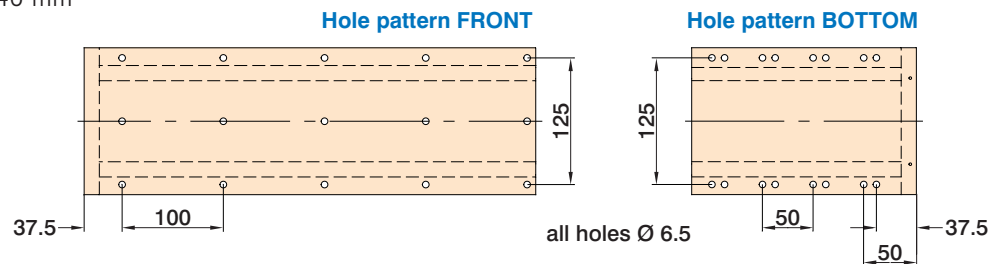

Hole diagram

Angle bracket WV 19

L 150 x W 221 x H 300 mm

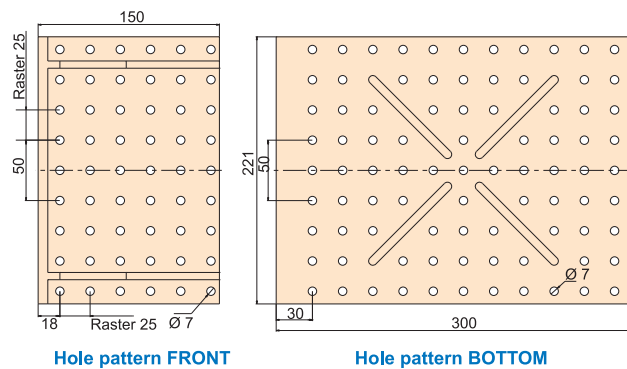

Accessories

Energy guidance chain



Dimensioned drawing
Energy guidance chain

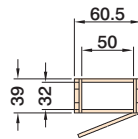

Energy guide chain 3

- VE 1 unit at 1 m
- Part no.: **219204 1000**

Connectors for energy chain 3

- with strain relief
- VE 1 kit
- Part no.: **219205 0002**

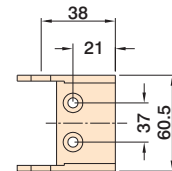
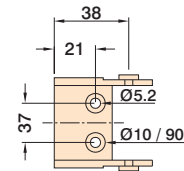
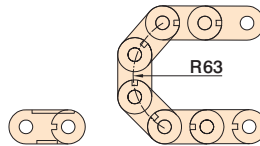

Tapped strips/sliding nuts

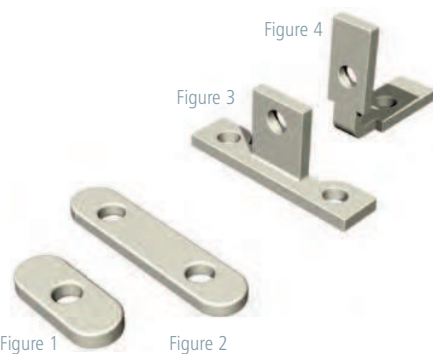

Figure 1

Figure 2

Figure 3

Figure 4

Tapped strips

- M6** (no figure)
- Galvanised
 - Ra 50 mm
 - 3 x VE 1 m piece
 - Part no.: **209011**

Sliding nut

- 2 × M6** (Figure 2)
- Galvanised
 - VE 50 pieces
 - Part no.: **209002 0004**

Special angle sliding nut

- 3 x M6** (Figure 3)
- Galvanised
 - VE 25 pieces
 - Part no.: **209022 0003**

Sliding nut

- M6** (Figure 1)
- Galvanised
 - VE 100 pieces
 - Part no.: **209001 0005**

Angle sliding nut

- 2 × M6** (Figure 4)
- Galvanised
 - VE 25 pieces
 - Part no.: **209021 0003**

Sliding nut

- M5** (no figure)
- Galvanised
 - VE 20 pieces
 - Part no.: **209006 0001**

Attachment kits

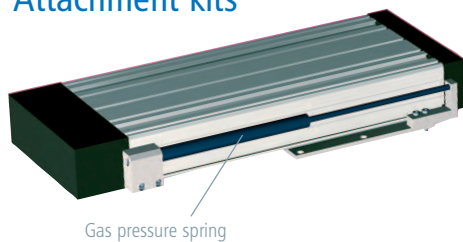

Gas pressure spring

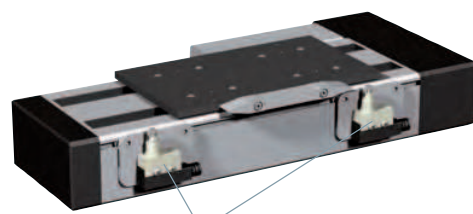

External limit switch

Gas strut attachment kit

- Hub 220 mm
- Nominal length 490 mm
- Part no.: **216450 0001**

Gas strut attachment kit

- Stroke 300 mm
- Nominal length 690 mm
- Part no.: **216451 0001**

Limit switch attachment kit for LES 4

- for external limit switches
- Process path reduction by approx. 40 mm
- Part no.: **216460 0001**

Limit switch attachment kit LES 6

- for external limit switches
- Process path reduction by approx. 40 mm
- Part no.: **216460 0003**

Limit switch attachment kit LES 5

- for external limit switches
- Process path reduction by approx. 40 mm
- Part no.: **216460 0002**

Mounting set for sealing air

- for LES4 - LES6
- Part no.: **216460 0006**

Linear unit

with linear motor

iLD 50-6

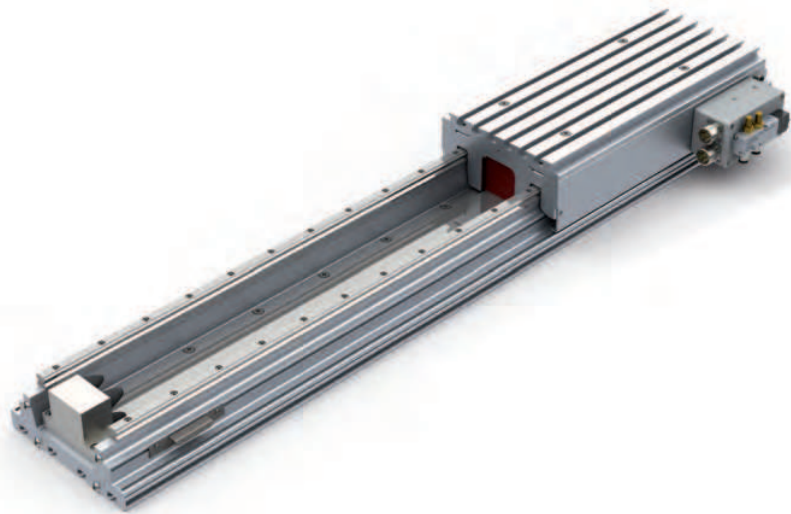

General

Linear units with linear motors are advantageous in precisely those areas where linear units with typical spindle drives are limited - they achieve high values of acceleration, offer pinpoint positioning and operate practically wear-free due to the absence of mechanical linkages.

Linear motors are increasingly used in linear technology machine tool applications, positioning systems and handling systems. Linear units with profile guides are particularly suitable for use in both machine tools and positioning systems.

isel iLD series linear units are constructed from rigid aluminium profiles. Guides consist of proven guide rails and recirculating ball shaft slots. A magnetic length-measuring system is also included. In this regard, isel linear motor units have the advantage of greater acceleration and higher traverse velocity. Iron-core linear motors can produce very high forces. An integrated brake is offered as an option, to allow the iLD to also be used in the vertical mode. The "made by isel" concept stands for optimum price/performance-ratio. This in turn means very short amortisation periods for customers.

Ordering data

Part number	L	L1
237110 0069	691	181
237110 0089	892	382
237110 0109	1094	584
237110 0129	1296	786
237110 0149	1497	987
237110 0169	1699	1189
237110 0190	1900	1390
237110 0210	2102	1592
237110 0230	2304	1794
237110 0250	2505	1995
237110 0270	2707	2197
237110 0290	2908	2398
237110 0311	3110	2600
237110 0331	3312	2802
237110 0351	3513	3003

Features

- Robust design in industrial quality
- Pinpoint positioning accuracy
- Wear-free design with no mechanical connecting links
- high dynamic acceleration up to 30 m/s²
- Multi-motor operation with multiple, separately moveable slides
- Extendable to 15 m travel

Options:

- Complete linear unit (see Order Information Table)
- Energy guide chain + guide plate to required length
- Brake MBPS1512ES1
- Motor cable, lengths 3, 5, 10 m
- Encoder cable, lengths 3, 5, 10 m, Linear motor to Metronix output stage
- Control package Metronix ARS 2310 (3-phase, 6 kVA, incl. configuration software)
- Control package Metronix ARS 2105 (1-phase, 2 kVA, incl. configuration software)
- Package B&R ACOPOS 1045 (3-phase, 2 kVA)
- Package B&R ACOPOS 1090 (3-phase, 4kVA)
- Package B&R ACOPOS 1180 (3-phase, 6 kVA)
- Switching unit Metronix output stage
- Drive controller ISEL iMD 40
- CAN CPC 12 positioning module
- Cable set iLD 50-6 for ISEL iMD 40

Linear unit

with linear motor

iLD 50-6

Technical specification

General	
Areas of application	Positioning axes for the semiconductor industry and for general industrial applications, CNC machine axis
Processing speed (m/s)	to 4.5
Acceleration (m/s ²)	to 30
Repeatability (mm)	< 0.01
Process path (mm)	181 to 3003, optionally extendible to 15000
Drive electronics	Servo amplifier, communication via CAN bus or analogue input (+/- 10 V)
Maintenance	Maintenance-free, rapid component replacement (MTTR approx. 2 hours)
Mechanics	
Profile	Bend-proof hollow chamber profile (isel ILF 6), straightness of 0.1 mm per 1 m length, Bending max. 0.2 mm per 1 m length under 50 kg load, max. load 100 kg
Guides	Profile rail guide Series 15 to DIN EN 120/20
Mechanical brake (optional)	Profile guide brake, pneumatically operated, Braking power Z-axis < 0.1 mm stationary, 50 mm at full speed
Stop position damping	Adjustable or parabolic spring for opposite side + pneumatic spring respectively
Installation options	X-axis, X,Y-axis, Z-axis
Maximum adjustment force	285 N
Electronics	
Limit position switch	inductive with adjustable limit position, circular plug connection (8x8x40)
Magnetic strip	isel MS 50
Linear motor	isel LS 50, iron core linear motor with magnetic rails, with or without audio signal, nominal current 6 A, peak current 15 A, max. feed force 600 N
Length measuring system	isel IMS, incremental measuring system
Motor / encoder connection	Protection type IP 67, M23 connecting socket for motor and encoder cable
Energy chain	Optional
Supported interfaces	Standard RS422 A,/A, B, /B optional z, /z, Option SIN/COS 1Vss +20%, -40%, Z and /Z Right-sign

Dimensioned drawing

